D	<i>Ersatzteilliste</i>	Motor- Sprühgerät	452-03 EU	Inhaltsverzeichnis	Seite
				Motor	2
				Behältergestell	5
				Sprührohr	6
				Ersatzteile	7
				Richtlinien für die Bestellung	7

GB	<i>Spare parts list</i>	Gasoline powered Mistblower	452-03 EU	Table of contents	Page
				Engine	2
				Tank frame	5
				Spray tube	6
				Spare parts	7
				Directions for ordering	7

F	<i>Liste de pièces de rechange</i>	Atomiseur à moteur	452-03 EU	Table des matières	Page
				Moteur	2
				Cassis réservoir	5
				Tube atomiseur	6
				Pièces de rechange	7
				Directives pour les commandes	7

E	<i>Lista de piezas de recambio</i>	Atomizador	452-03 EU	Indice	Página
				Motor	2
				Deposito	5
				Tubo pulverizador	6
				Piezas de recambio	7
				Directivas de pedido	7



Bild-Nr. Pos.-No. No.Pos. Pos.-No.	Bestell-Nr. Order-No. No. de Cde Ref.-Nr.	Menge Quantity Nombres Cantidad	Motor	Engine	Moteur	Motor
1	14791	1	Kurbelwelle, kompl.	Crankshaft, compl.	Vilebrequin complet	Ciguenal completo
2	10483	1	Kugellager 15x35x13-C4	Ball bearing	Roulement a billes epaule	Cojinete de bolas
3	10547	1	Wellendichtring 15x29,6x4	Oil seal	Joint spy dfs	Reten radial dfs
4	10285	1	Scheibe 33, 1x38x1	Washer	Rondelle	Arandela
5	10482	1	Kugellager 15x42x13 mm	Ball bearing	Roulement a billes	Cojinete de bolas
6	11803	1	Lagerring AL	Ring	Anneau	Anillo
7	10542	1	Wellendichtring 15x28x5	Oil seal 15X28X5	Joint spy	Reten radial
8	10514	1	Nadelkäfig 9x13x12,5	Needle Bearing	Roulement aig. pist.	Casquillo de cojin.
9	14792	1	Zylinder + Kolben, Reparatursatz enth.: (-> 9 - 15	Cylinder + piston, repair kit incl. (-> 9 - 15	Kit de reparation cylindre + piston y inclus (-> 9 - 15	Kit de reparacion cilindro + piston incl. (-> 9 - 15
10	10660	1	O-Ring 38x2 NBR 70Shore	O-Ring	Joint torique	Anillo
11	14793	2	Dichtungsteil Zyl.- Kurbelgehäuse	gasket cyl.-crankcase	Joint cylindre - carter de vilebrequin	Junta cilindro - carter del ciguenal
12	12150	1	Kolben Ø 46 mm enth.: (-> 12 - 15	Piston incl. (-> 12 - 15	Piston + axe de piston y inclus (-> 12 - 15	Piston + bulon de piston incl. (-> 12 - 15
13	11864	2	Kolbenring 46x1,5 mm	Piston ring	Segment de piston	Anillo de piston 46x1,5
14	10585	2	Sicherungsring 9x0,8 mm	Circlip	Clips d'axe de piston	Anillo de seguridad
15	11791	1	Kolbenbolzen 9/5x32 (-))	Piston pin (-))	Boulon de piston (-))	Perno de embolo (-))
16	14794	1	Kurbelgehäuse	Crankhousing	Vilebrequin	Ciguenal
17	10165	6	Zyl.-Schraube M5x40 KT T25	Screw M5x40mm	Vis torx	Tornillo torx
18	12222	1	Zündkerze WSR6F200	Spark Plug	Bougie d'allumage wsr	Bujia
19	14795	1	Vergaserstutzendichtung	Manifold gasket	Joint manchon du carb.	Junta tapa del carb.
20	14796	1	Vergaserstutzen	Manifold	Manchon du carburateur	Tapa del carburador
21	14797	1	Auspuffdichtung	Exhaust Gasket	Joint d'echappement	Junta del escape
22	14868	1	Schalldämpfer VS	Muffler	Silencieux	Silenciador
23	10166	2	Zyl. Schr. M5x20 T25 klKopf	Screw	Vis	Tornillo
24	10162	2	Zyl.Schr. T25-M5x20	Screw M5x20	Vis torx	Tornillo
25	10268	2	Scheibe 5,3	Washer	Rondelle	Arandela
26	10244	2	4KT Mutter M5 DIN 557	Square Screw Nut M5	Ecrou carre	Tuerca cuadrada
27	10394	2	Sicherungsscheibe 10	Locking washer 10	Rondelle crantee	Seguro
28	10215	2	6KT Mutter M10x1 DIN 934	Hexagonal Nut M10x1	Ecrou	Tuerca hexagonal
29	10265	1	Scheibe 4,3 DIN 433	Washer	Rondelle	Arandela
30	10398	1	Sicherungsscheibe 4	Circlip	Rondelle crantee	Arandela estriada
31	10155	2	Zylinderschraube M4x20	Screw KT	Vis torx	Tornillo
32	14799	1	Polrad D78	Flywheel	Volant magnetique	Volante magnetico
33	14800	1	Zündmodul digital	Digital Ignition	Bobine d'allumage digital	Bobina de encendido d.
34	14801	1	Vergaser SOLO-7	Carburetor	Carburador	Carburateur
35	14802	1	Vergaserdichtung	Carburetor Gasket	Joint carburateur	Junta carburador
36	14803	1	Vergaser-Reparatursatz	Carburetor repair kit	Kit de reparation carb.	Kit de reparacion carb.
37	10061	1	Verstellschraube M6x14	Adjust Screw	Vis	Tornillo
38	10220	1	6KT. Mutter M6 DIN 4398	Hexagonal Nut M6	Ecrou	Tuerca
39	10162	2	Zyl.Schr. T25-M5x20	Screw M5x20	Vis torx	Tornillo
40	11821	2	Stützlasche	Support Flap		
41	10185	2	Schraube 6x16 KT	Screw 6x16	Vis parker	Tornillo
42	10187	2	Schraube 6x35 KT	Screw 6 x 35	Vis parker	Tornillo
43	10181	1	Schraube 5x20 KT	Screw 5x20	Vis	Tornillo
44	10268	1	Scheibe 5,3	Washer	Rondelle	Arandela
45	10167	2	Zylinderschraube M5x60 KX	Screw M5x60	Vis torx	Tornillo
46	14805	1	Filtergehäuse	Filter Housing	Carter de filtre	Caja del filtro
47	14806	1	Filtereinsatz	Filter Element	Element filtrant	Elemento filtrante
48	14807	1	Filterdeckel	Filter Cover	Couvercle de filtre	Tapa del filtro
49	14890	1	Benzintank	Fuel Tank	Reservoir d'essence	Deposito de gasolina
50	14817	3	PT-Schraube 6x22	Screw	Vis	Tornillo
51	14889	1	Reparatursatz ET Kraftstoffschläuche	Repair kit fuel hoses	Kit de reparation tuyaux d'essence	Kit de reparacion mangueras de gasolina
52	14810	1	Tankverschluß, kompl. enth. (-> 52, 53	Tank cap, compl. incl. (-> 52, 53	Bouchon reservoir d'essence complet y inclus (-> 52, 53	Tapon de gasolina completo incl. (-> 52, 53
53	14811	1	Dichtung 24,5X40,5X2 (-)	Rubber Sealing (-)	Joint bouchon de reservoir (-)	Junta tapon gasolina (-)
54	14888	1	Reparatursatz ET Bowdenzug+Kabel	Repair kit bowden cable	Kit de reparation cable bowden	Kit de reparacion cable bowden
55	12057	1	Haltering	Ring	Anneau	Anillo
56	14645	1	Gebläsegehäuse Ansaugseite	Blower Housing Suction Side	Carter de soufflerie cote d'aspiration	Caja del ventilador aspirante
57	14804	1	Gebläserad	Fan Wheel	Roue de ventilateur	Rueda de ventilador
58	14642	1	Gebläsegehäuse Motorseite	Blower Housing Engine Side	Carter de soufflerie cote moteur	Caja del ventilador a lado motor
59	10181	12	Schraube 5x20 KT	Screw 5x20	Vis	Tornillo
60	10213	2	6KT. Mutter M5 DIN 934	Hexagonal Nut M5	Ecrou hex.	Tuerca hex.
61	10167	2	Zylinderschraube M5x60 KX	Screw M5x60	Vis torx	Tornillo
62	14814	1	Gebläsekrümmer	Blower Elbow	Coude ventilateur	Codo ventilador

Motor-Sprühgerät, Gasoline powered Mistblower, Atomiseur à moteur, Atomizador 452-03

63	14646	1	Motorabdeckung	Engine cover	Carter de protection moteur	Cobertura del motor
64	10181	2	Schraube 5x20 KT	Screw 5x20	Vis	Tornillo
65	14812	1	Starter kompl. enth. (-> 65 - 69	Starter compl. incl. (-> 65 - 69	Lanceur complet y inclus (-> 65 - 69	Tapa arranque completa incl. (-> 65 - 69
66	12364	1	Federkassette	Spring Cassette	Ressort de lanceur a ergot	Caja de resorte
67	14813	1	Starterseil 3x1415	Starter rope 3x1415	Corde de lanceur	Cuerda de arranque
68	15011	1	Starterklinke	Starter pawl	Cliquet de lanceur	Trinquete de arranque
69	15012	1	Kulissenführung <-)	Starter pawl clip <-)	Ressort cliquet lanceur <-)	Muelle de trinquete <-)
70	10161	4	Zyl.Schraube KT M5x16	Screw	Vis	Tornillo
71	12422	1	Belueftungsstutzen vs.	Ventilation socket	Soupape d' aeration	Munon
72	15185	1	Schlauchtülle FKM	Hose grommet FKM	Embout de tuyau FKM	Portatubo FKM
73	14830	1	Filter Benzin D20	Fuel filter D20	Filtre a essence D20	Filtro gasolina D20

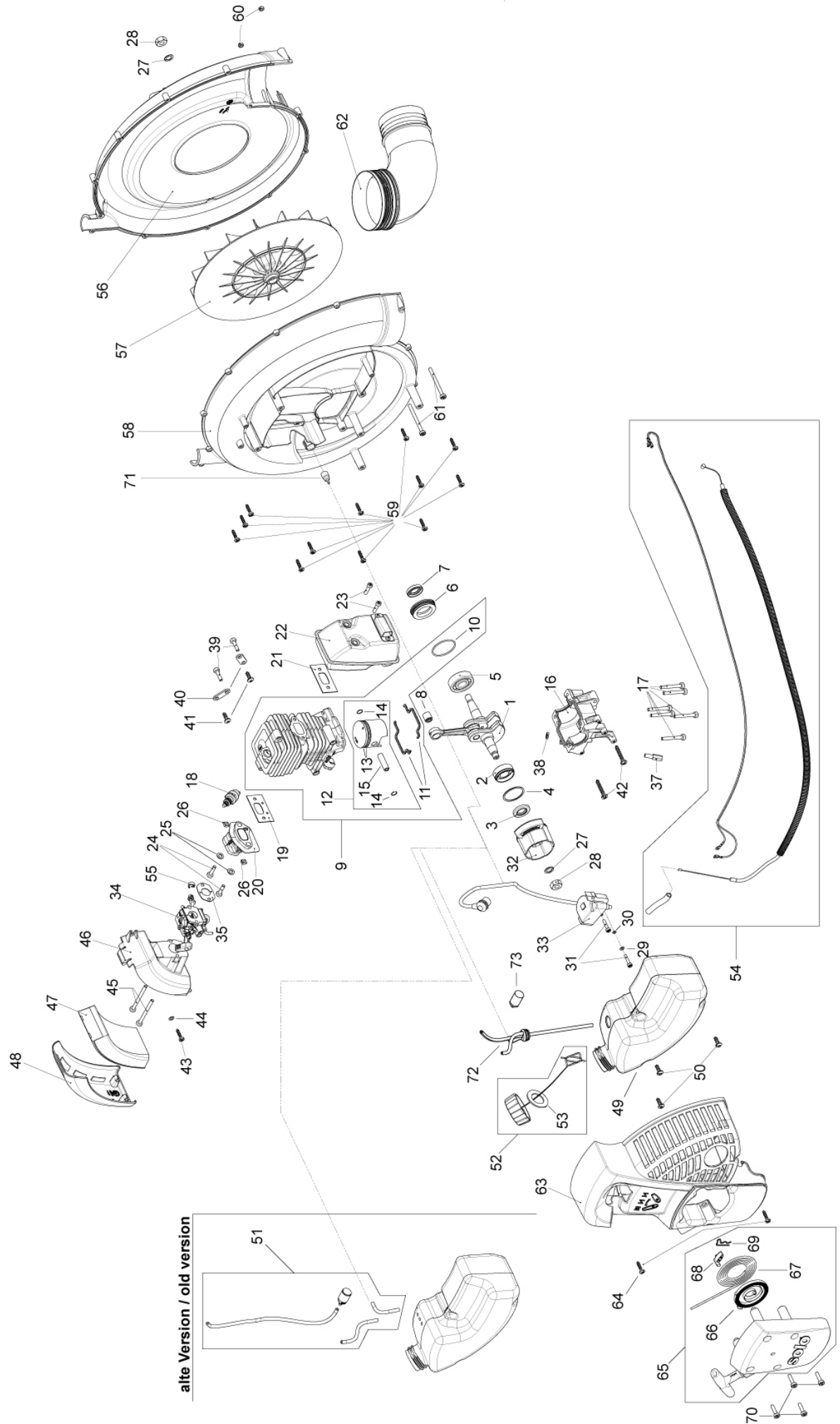

Bild-Nr. Pos.-No. No.Pos. Pos.-No.	Bestell-Nr. Order-No. No. de Cde Ref.-Nr.	Menge Quantity Nombres Cantidad	Behältergestell	Tank frame	Cassis réservoir	Deposito
1	10153	4	Linsenschraube M6x14 mm	Screw	Vis parker	Tornillo
3	10682	1	O-Ring 30x3 mm	Ring	Joint torique	Anillo
4	10682	1	O-Ring 30x3 mm	Ring	Joint torique	Anillo
5	13056	1	Schraubkörper	Threaded collar	Vis de corps	Union roscada
6	13056	1	Schraubkörper	Threaded collar	Vis de corps	Union roscada
7	13059	1	Abflußstopfen 10/32x22/49 mm	Drainage plug	Bouchon de raccordement ext.	Tapon
8	13059	1	Abflußstopfen 10/32x22/49 mm	Drainage plug	Bouchon de raccordement ext.	Tapon
9	10738	350mm	Schlauch 8x2 mm	Hose	Tuyau clair 8x2 mm	Tubo
10	13279	1	Einfüllkorb, kompl. enth. (-> 10, 11)	Liquid strainer, compl. incl. (-> 10,11)	Tamis de remplissage y inclus -> 10,11	Cesta de relleno incl. (-> 10,11)
11	13061	1	Schutzkappe 21x27 mm (-)	Cap (-)	Capuchon (-)	Tapa (-)
12	14732	1	Behälterdeckel	Tank lid	Couvercle reservoir rouge sans percage	Tapa deposito roja sin agujero
13	12747	1	Dichtring 99,5x111 mm	Gasket	Joint torique	Junta torica
14	13371	2	Tragegurt + Haken	Strap + hook	Bretelle et crochet	Cinturon y gancho
17	13130	2	Gurthalter	Strap holder	Porte-bretelle	Soporte cinturon
23	12753	1	Kugelbalg	Siphon	Manchette	Manguito
24	11272	1	Drahtschelle 51x2,5 mm	Clamp	Collier ressort	Abrazadera
27	10272	4	Scheibe 6,4 mm	Washer	Rondelle	Arandela
28	11277	4	Dämpfungsfeder 3x22x24,5	Av spring	Ressort amortisseur	Resorte av
29	10084	4	Sechskantschraube M6x16 mm	Screw	Vis 6 pans	Tornillo
30	10258	4	Sechskantmutter M6	Nut	Ecrou crante	Tuerca
31	11511	1	Rückenkissen	Back cushion	Coussinet	Almohadilla
32	10452	3	Steckniet 5,7x18 mm	Cushion rivet	Rivet plastique	Remache
33	10460	5	Stopfen 7,2 x 15 mm	Rivet	Rivet	Remache



Bild-Nr. Pos.-No. No.Pos. Pos.-No	Bestell-Nr. Order-No. No. de Cde Ref.-Nr.	Menge Quantity Nombres Cantidad	Blasrohr, Handgriff	Air Tube, handle	Tube de soufflerie, guidon	Tubo soplador, empuñadura
1	12780	1	Faltenschlauch 92D	Pleated hose	Tuyau pliable	Tubo plegable
2	10142	1	Linsenschraube 5x25 mm	Screw	Vis	Tornillo
3	10832	1	Klemmschelle 83	Clamp	Collier	Abrazadera
4	13383	1	Blasrohr 63/65x590 mm	Tube	Tube	Tubo
5	14931	1	Handgriff, kompl. enth. (-> 5 - 15	Handle, compl. incl. -> 5 - 15	Poignée, compl. y inclus -> 5 - 15	Empuñadura, compl. incl. -> 5 - 15
6	13480	1	Achse D10/6/4,8x15/9/4,2	Arbor	Arbre	Eje
7	13211	1	Sicherungshebel	Safety lever	Levier de securite	Palanca de seguridad
8	13213	1	Gashebel	Throttle lever	Levier de gas	Palance de gas
9	11302	1	Schenkelfeder D5,2x1x13,2/14,8	Spring	Ressort	Resorte
10	10405	1	Si.Scheibe 6	Safety washer	Rondelle de securite	Arandela de seguridad
11	11304	1	Schenkelfeder D7x1x17/18	Legspring	Ressort	Resorte de brazos
12	14888	1	Reparaturset ET Bowdenzug+Kabel	Repair kit bowden cable	Kit de reparation cable bowden	Kit de reparacion cable bowden
13	11375	1	Schalter Kurzschluss	Short circuit switch	Bouton marche arret	Interruptor
14	10177	3	Linsenschraube 4x20 mm	Screw	Vis	Tornillo
15	10157	3	Schraube 4x25 mm (-)	Screw (-)	Vis (-)	Tornillo (-)
16	13468	1	Abstellhahn	Cock	Robinet	Llave
17	10148	2	Linsenschraube 5x30 mm	Screw	Vis	Tornillo
18	10067	1	Zylinderschraube M5x50/30 mm	Screw	Vis cyl.	Tornillo cil.
19	10244	1	4 Kt.Mutter M5	Square nut	Ecrou carre m5	Tuerca cuadrada
20	10853	1	Schelle 68 x 10 mm	Clamp	Collier matiere synthetique	Abrazadera
21	12874	1	Weitstrahldüse	Wide-angle nozzle	Buse à diff. Large	Boquilla
22	13197	1	Breitstrahlgitter	Diffuser screen	Grille à diff. Large	Pasador
23	13535	1	Sprühdüse 50/62,5 enth. (-> 23 - 28	Spray nozzle incl. -> 23 - 28	Buse complete y inclus -> 23 - 28	Tobera incl. -> 23 - 28
24	13044	1	Düsenrohr 6/7x54 mm	Tube	Tube de diffusion	Tubo
25	10174	1	Zylinderschraube M4x25 mm	Screw	Vis cyl.	Tornillo
26	10216	1	Sechskantmutter M4	Nut	Ecrou	Tuerca
27	13008	1	Dosierhülse 1,7/2,5/4/6,5	Dosage sleeve	Douille de dosage noir	Casquillo
28	10677	1	O-Ring 12x2 (-)	Ring(-)	Joint torique (-)	Anillo (-)
29	10738	840 mm	PVC Schlauch 8x2 mm	Hose	Tube	Tubo
30	10738	495 mm	PVC Schlauch 8x2 mm	Hose	Tube	Tubo

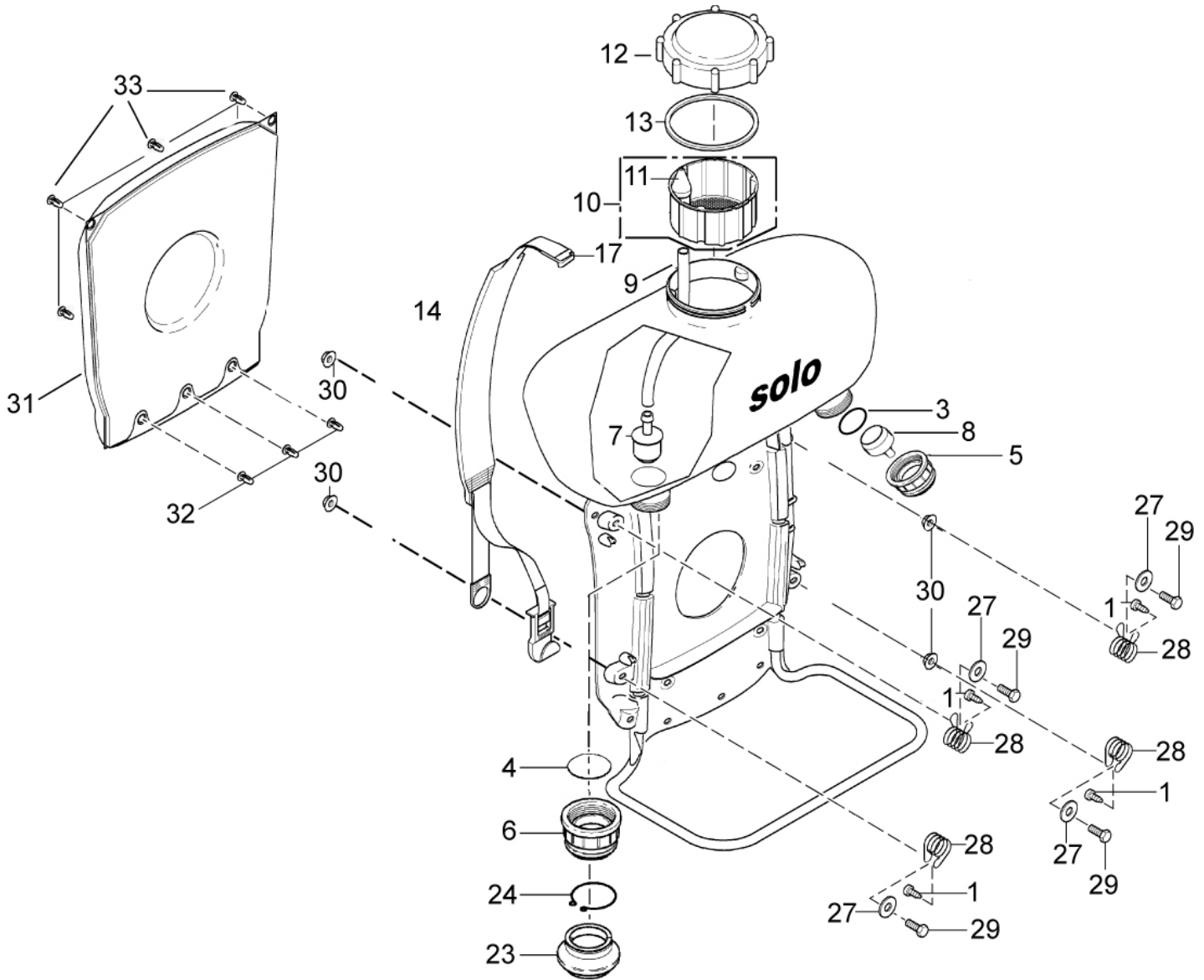
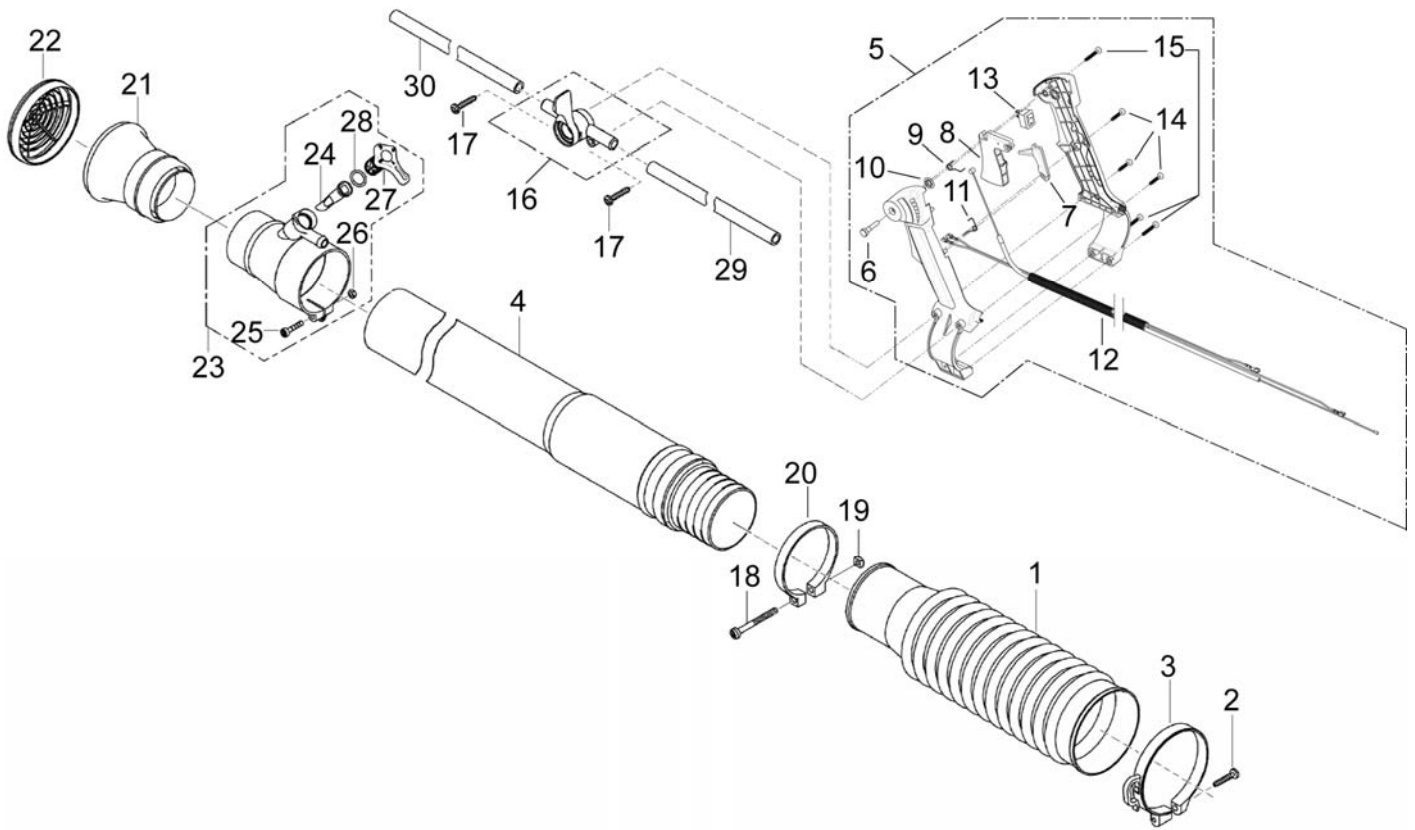