

D	<i>Ersatzteilliste</i>	Akku- Druckspritze	416 Li	Inhaltsverzeichnis	Seite
				Tragegestell, Pumpe, Elektronik	2
				Behälter, Tragegurt	4
				Spritzrohr	5
				Ersatzteile	6
				Bestell-Richtlinien	6
GB	<i>Spare parts list</i>	Backpack sprayer with rechargeable battery	416 Li	Table of contents	Page
				Carrying frame, pump	2
				Tank, Carrying strap	4
				Spray wand	5
				Spare Parts	6
				Directions for Ordering	6
F	<i>Liste de pièces de rechange</i>	Pulvérisateur à batterie	416 Li	Table des matières	Page
				Cadre porteur, pompe	2
				Réservoir, bretelle	4
				Tube de pulvérisation	5
				Pièces de rechange	6
				Directives pour les commandes	6
E	<i>Lista de piezas de recambio</i>	Rociador a presión con batería	416 Li	Indice	Página
				Bastidor, bomba	2
				Deposito, cinturón portador	4
				Tubo	5
				Piezas de recambio	6
				Directivas de pedino	6



Bild-Nr. Pos.-No. Pos.-No.	Bestell-Nr. Order-No. No. de Cde Ref.-Nr.	Menge Quantity Nombres Cantidad	Tragegestell, Pumpe, Elektronik	Carrying frame, pump	Cadre porteur, pompe	Bastidor, bomba
1	00 18 274	12	Linsenschraube 5x16 mm	Screw	Vis	Tornillo
2	40 74 126	2	Kappe	Cap	Capuchon	Caperuza
3	40 74 275	2	Gurtbefestigung	Strap holder	Fixation de bretelle	Fijacion
4	00 98 101	1	Rückenkissen	Back cushion	Coussin dorsal	Almohadilla
5	40 73 222	1	Rückenplatte	Back plate	Plaque dorsale	Chapa
6	00 61 361	4	Filz 15x55x1,5 mm	Felt	Feutre	Fieltro
7	00 44 144	6	Nieten 5,7x18 mm	Rivet	Rivet	Remache
8	40 35 119 25	1	Rohrbügel rechts	Frame right	Tube coudé droite	Estribo
9	40 46 100 25	2	Spannbügel	Frame	Etrier de tension	Estribo
10	40 73 132	1	Stützstrebe	Support bracket	Antibalancant	Tirante
11	00 18 275	2	Linsenschraube 5x30mm	Screw	Vis	Tornillo
31	00 18 258	2	Linsenschraube 5x18 mm	Screw	Vis	Tornillo
32	00 18 356	4	Linsenschraube 4x20 mm	Screw	Vis	Tornillo
33	00 18 340	2	Zylinderschraube M5x40 mm	F.H. screw	Vis	Tornillo
34	00 28 137	2	Sechskantmutter M5	Hex. nut	Ecrou	Tuerca
35	60 43 107	1	Flanschblech	Flange plate	Tôle de bride	Chapa
36	40 35 120 25	1	Rohrbügel links	Frame left	Tube coudé gauche	Estribo
37	44 00 317	1	Pumpe	Pump	Pompe	Bomba
38	00 64 234	450 mm	Schlauch10x3 mm	Hose	Tuyau	Tubo
39	00 66 192	4	Schelle 8-16 mm	Clamp	Collier	Abrazadera
62	40 73 166	1	Bodenplatte	Base plate	Plaque de base	Chapa
63	48 00 214	1	Abstellhahn	Cock	Robinet	Llave
64	00 64 137	360 mm	Schlauch10x2 mm	Hose	Tuyau	Tubo
65	00 64 137	320 mm	Schlauch10x2 mm	Hose	Tuyau	Tubo
66	00 18 257	2	Linsenschraube 5x25 mm	Screw	Vis	Tornillo
67	53 00 648	1	Klettgurt	Hookand loop strap	Bretelle	Cinturon portador
68	50 42 704	1	Lasche	Flap	Eclisse	Eclisa
69	00 84 112	1	Ladekabel	Plug	Fiche	Enchufe
70	41 00 110	1	Seitenteil rechts enth. (-> 70-76	Side part right incl. (-> 70-76	Element lateral y inclus: (-> 70-76	Parte Lateral incl. (-> 70-76
71	00 84 108	1	Schalter	Switch	Interrupteur	Interruptor
72	00 84 054	1	Feinsicherungshalter	Fuse holder	Support	Suporte
73	00 84 055	1	Sicherung Glas 5x20 mm 4 A	Ceramic fuse 5x20 4A	Fusible ceramique	Fusible ceramico
74	00 84 115	1	Platine	Plate	Platine	Platino
76	00 18 354	1	Linsenschraube 4x12 mm <-)	Screw <-)	Vis <-)	Tornillo <-)
77	00 84 180	1	Batterie Li-Ionen 7,8Ah/11,1 V	Battery Li-Io 7.8 Ah 11.1V	Batterie Li-Ion	Bateria De Iones
78	40 74 206	2	Scharnier	Hinge	Charniere	Charnela
79	40 73 168	1	Seitenteil links	Side part left	Element lateral	Parte Lateral
80	00 28 149	2	Blechmutter 4,8 mm	Nut	Ecrou de carrosserie	Tuerca
81	20 74 682 25	2	Verschlussbolzen	Bolt	Boulon	Perno
82	00 94 252	2	Gummi Elemente	Rubber spacer	Butee de Capot	Elemento de goma
83	00 84 755	1	Ladegeraet Li-Ionen	Battery charger Li-Io	Chargeur batterie Li-Ion	Cargador Li-Ion
84	00 66 317	1	Kabelband 140x9	Cable band	Serre cable	Cinta de cable
85	00 66 296	1	Wellschlauchhalter	Corrugated hose clamp	Support tube	Fijacion del tubo flexible ondulado



Bild-Nr. Pos.-No. Pos.-No. Pos.-No.	Bestell-Nr. Order-No. No. de Cde Ref.-Nr.	Menge Quantity Nombres Cantidad	Behälter, Tragegurt	Tank, Carrying strap	Réservoir, bretelle	Deposito, cinturon portador
12	42 00 357	1	Behälter 20l komplett enth. (-> 12-22)	Tank 20l cpl. incl. (-> 12-22)	Réservoir 20L cpl. y inclus: (-> 12-22)	Deposito 20l incl. (-> 12-22)
13	42 00 142	1	Behälter 20 l	Tank 20l	Réservoir 20L	Deposito 20l
14	42 00 104	2	Einfüllkorb mit Sieb	Filler basket	Entonnoire	Cesta
15	43 00 341 01	2	Tragegurt	Carrying strap	Bretelle	Cinturon portador
16	40 74 412 25	2	Gurthalter	Strap holder	Port-bretelle	Fijacion
17	42 00 330	1	Deckel enth. (-> 17-20)	Cover incl. (-> 17-20)	Couvercle y inclus (-> 17-20)	Tapa incl (-> 17-20)
18	00 62 331	1	O-Ring 124x4,5 mm	O-ring	Joint torique	Anillo
19	40 61 464	1	Ventilplatte	Valve plate	Joint de soupape	Chapa
20	40 74 123	1	Belüftungsdeckel (-)	Cover (-)	Couvercle d'aération (-)	Tapa (-)
21	0061376	2	Klettband 60x20 Flauschs.	Velcro fastener	Bande velcro	Cinta
22	0061377	2	Klettband 60x20 Hakenseite (-)	Velcro fastener (-)	Bande velcro (-)	Cinta (-)
83	40 73 121	1	Spritzrohrhalterung	Tube support	Support de tube	Soporte
84	49 00 109	1	Hüftgurt	Waist belt	Ceinture	Cinturon

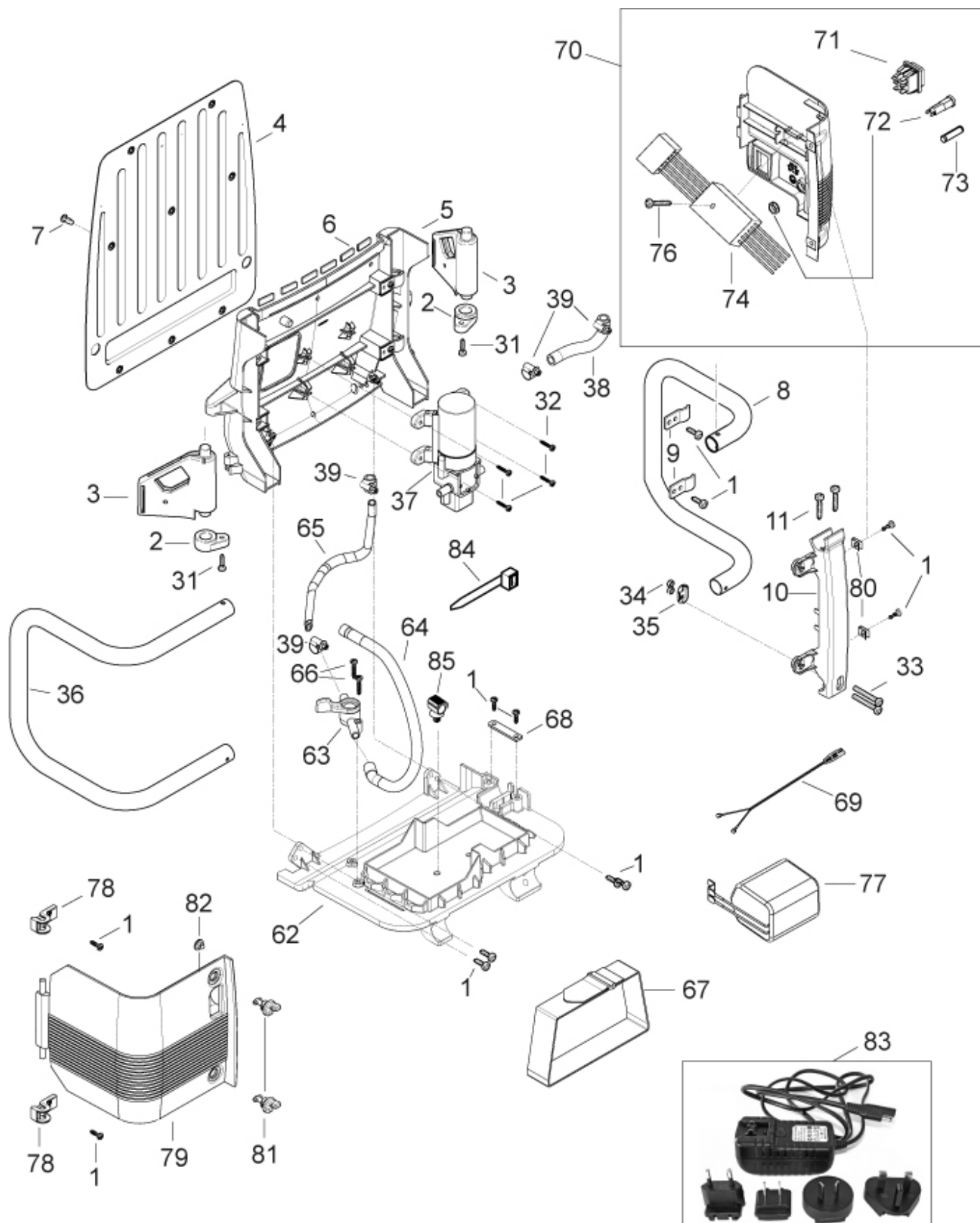

Bild-Nr. Pos.-No. Pos.-No. Pos.-No.	Bestell-Nr. Order-No. No. de Cde Ref.-Nr.	Menge Quantity Nombres Cantidad	Spritzrohr	Spray wand	Tube de pulvérisation	Tube
1	49 00 491	1	Teleskopspritzrohr 50-90 enth. (-> 1-3	Telescopic lance incl. (-> 1-3	Tube telescopique y inclus (-> 1-3	Varilla telescopica incl. (-> 1-3
2	00 62 356	1	O-Ring 16x3 mm	O-ring	Joint torique	Anillo
3	40 74 337	1	Überwurfmutter R 3/4" <-)	Screw cap <-)	Ecrou de raccord <-)	Tuerca <-)
5	00 62 115	2	O-Ring 10x2 mm	O-ring	Joint torique	Anillo
6	40 74 527	1	Winkelstück R 3/8"	Elbow	Coude	Codo
7	27 00 316	1	Filter Kug. Ventil	Ball valve filter	Filtre anti-goutte	Filtro valvula de bola
8	00 62 106	1	O-Ring 12x2 mm	O-ring	Joint torique	Anillo
9	40 74 506	1	Düse Flachstrahl	Flat spray nozzle	Gicleur à jet plat	Tobera de chorro ancho
10	40 74 148	1	Überwurfmutter R 3/8" <-)	Screw cap <-)	Ecrou de raccord <-)	Tuerca <-)
14	00 64 632	1,3 m	Schlauch 10x3 mm	Hose	Tuyau	Tube
15	40 74 987	1	Überwurfmutter R 3/4"	Screw cap	Ecrou de raccord	Tuerca
16	00 31 347	1	Scheibe 17x24x1 mm	Washer	Rondelle	Arandela
17	40 74 500	1	Klemmstück	Clamping piece	Pièce de serrage	Abrazadera
18	00 62 271	1	O-Ring 10x3 mm	O-ring	Joint torique	Anillo
19	48 00 243	1	Handventil enth. (-> 19-28	Shut-off valve incl. (-> 19-28	Robinet d'arrêt y inclus (-> 19-28	Empunadura incl. (-> 19-28
20	48 00 170	1	Ventil m. Haltebuegel enth. (-> 20-25	Shut-off handle incl. (-> 20-25	Poignee robinet y inclus (-> 20-25	Llave de liquido incl. (-> 20-25
21	06 10 402	1	Reparaturset Handventil enth. (-> 21, 22	Repair kit incl. (-> 21, 22	Jeu de réparation y inclus (-> 21, 22	Juego rep. incl. (-> 21, 22
22	00 62 258	1	O-Ring 16x3 mm <-)	O-ring <-)	Joint torique <-)	Anillo <-)
23	40 74 335 25	1	Handhebel	Lever	Levier	Palanca
24	40 74 295 25	1	Bolzen 4,8x26,5 mm	Bolt	Goujon	Perno
25	40 74 329 25	1	Haltebügel <-)	Support bracket <-)	Crochet <-)	Estribo <-)
26	40 74 338	1	Überwurfmutter R 3/4"	Screw cap	Ecrou de raccord	Tuerca
27	49 00 362	1	Manometer enth. (-> 27-28	Pressure gauge incl. (-> 27-28	Manometre y inclus (-> 27-28	Manometro de presión incl. (-> 27-28
28	00 62 249	1	O-Ring 5x3 mm <-))	O-ring <-))	Joint torique <-))	Anillo <-))
29	00 66 192	1	Schelle 8-16 mm	Clamp	Collier	Abrazadera

Bestell-Nr. Order-No. No. de Cde Ref.-Nr.	Menge Quantity Nombres Cantidad	Seite Page Page Pagina	Bestell-Nr. Order-No. No. de Cde Ref.-Nr.	Menge Quantity Nombres Cantidad	Seite Page Page Pagina	Bestell-Nr. Order-No. No. de Cde Ref.-Nr.	Menge Quantity Nombres Cantidad	Seite Page Page Pagina
00 18 257	2	2	00 66 296	1	2	40 74 275	2	2
00 18 258	2	2	00 66 317	1	2	40 74 295 25	1	5
00 18 274	12	2	00 84 054	1	2	40 74 329 25	1	5
00 18 275	2	2	00 84 055	1	2	40 74 335 25	1	5
00 18 340	2	2	00 84 108	1	2	40 74 337	1	5
00 18 354	1	2	00 84 112	1	2	40 74 338	1	5
00 18 356	4	2	00 84 115	1	2	40 74 412 25	2	4
00 28 137	2	2	00 84 180	1	2	40 74 500	1	5
00 28 149	2	2	00 84 755	1	2	40 74 506	1	5
00 31 347	1	5	00 94 252	2	2	40 74 527	1	5
00 44 144	6	2	00 98 101	1	2	40 74 987	1	5
00 61 361	4	2	06 10 402	1	5	41 00 110	1	2
00 61 376	2	4	20 74 682 25	2	2	42 00 104	2	4
00 61 377	2	4	27 00 316	1	5	42 00 142	1	4
00 62 106	1	5	40 35 119 25	1	2	42 00 330	1	4
00 62 115	2	5	40 35 120 25	1	2	42 00 357	1	4
00 62 249	1	5	40 46 100 25	2	2	43 00 341 01	2	4
00 62 258	1	5	40 61 464	1	4	44 00 317	1	2
00 62 271	1	5	40 73 121	1	4	48 00 170	1	5
00 62 331	1	4	40 73 132	1	2	48 00 214	1	2
00 62 356	1	5	40 73 166	1	2	48 00 243	1	5
00 64 137	360 mm	2	40 73 168	1	2	49 00 109	1	4
00 64 137	320 mm	2	40 73 222	1	2	49 00 362	1	5
00 64 234	450 mm	2	40 74 123	1	4	49 00 491	1	5
00 64 632	1,3 m	5	40 74 126	2	2	50 42 704	1	2
00 66 192	4	2	40 74 148	1	5	53 00 648	1	2
00 66 192	1	5	40 74 206	2	2	60 43 107	1	2

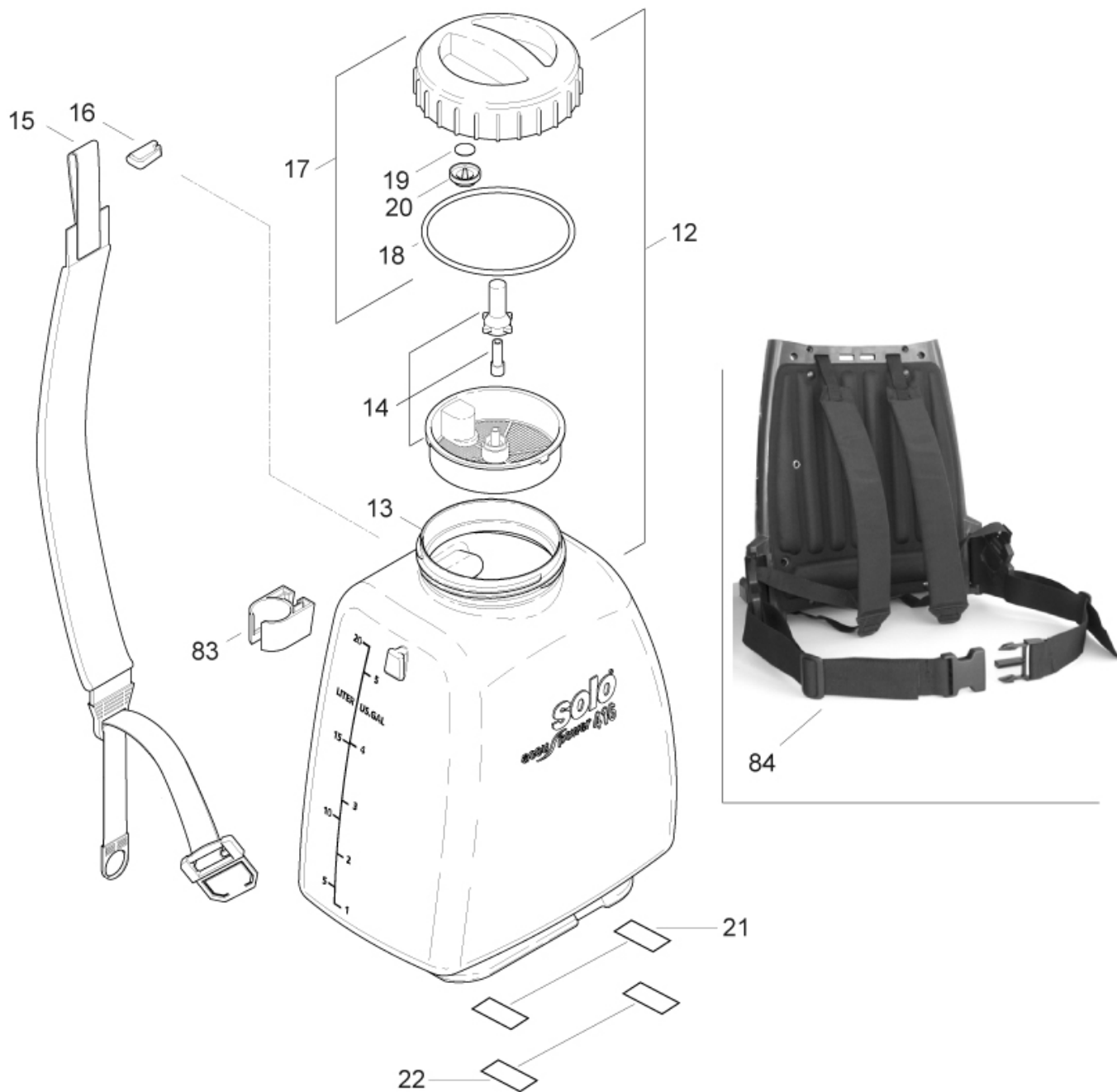
D

Allgemeine Richtlinien für die Bestellung von Original SOLO Ersatzteilen:

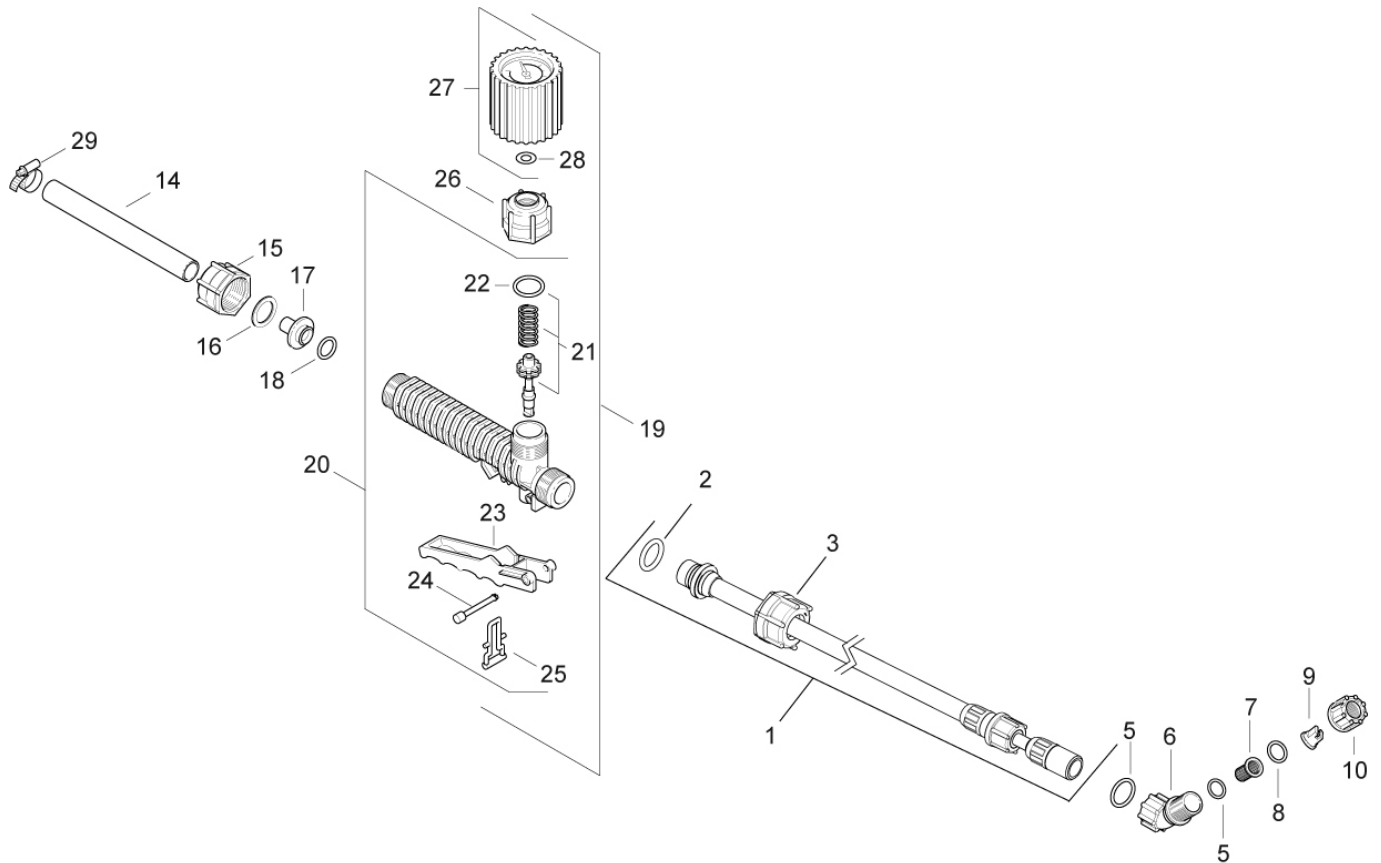
Voraussetzung für eine reibungslose Erledigung sind folgende Angaben:

1. Ersatzteil-Bestellnummer
2. Gewünschte Anzahl
3. Typenbezeichnung des Geräts

Diese Ersatzteilliste ist für die Lieferung und Ausstattung von SOLO Erzeugnissen unverbindlich.

Im Interesse der technischen Weiterentwicklung bleiben Konstruktionsänderungen vorbehalten.

GB

General Directions for Ordering Original SOLO Spare Parts:

For correct and diligent processing of your order, please give the following information:

1. Spare Part number
2. Quantity
3. Model and serial number
4. Shipping instructions

Delivery is made in accordance with our general sales and delivery conditions. This spare parts list is non-committal for us with regard to delivery and layout of SOLO products. In favour of technical improvements, design modifications are subject to change without notice.

F

Directives générales pour les commandes de pièces de rechange d'origine SOLO:

Il est indispensable de préciser dans toutes les commandes de pièces:

1. le numéro de référence de la pièce
2. la quantité
3. le type de la machine
4. le mode d'expédition

Les livraisons sont effectuées dans le cadre de nos conditions générales de vente.

Toutes modifications réservées.

E

Directivas Generales de pedido de la firma SOLO:

Por adelantado de un arreglo sin dificultades necesitamos siguientes indicaciones:

1. Número de repuesto
2. Numero de cantidad
3. Modelo y número de serial
4. Instrucción de Envío

Esta lista de repuestos no es obligatoria para los envíos y/o forma de equipo de los productos SOLO.

En el interés del constante desarrollo debemos reservarnos el derecho de cambios.